



UNIVERSITY COLLEGE TATI (UC TATI)

FINAL EXAMINATION QUESTION BOOKLET

COURSE CODE	: BET 3013
COURSE	: POWER ELECTRONICS
SEMESTER/SESSION	: 2-2023/2024
DURATION	: 3 HOURS

Instructions:

1. This booklet contains 4 questions. Answer **ALL** questions.
2. This Final Exam is an **OPEN BOOK**.
3. All answers should be written in answer booklet.
4. Write legibly and draw sketches wherever required.
5. If in doubt, raise your hands and ask the invigilator.

DO NOT OPEN THIS BOOKLET UNTIL YOU ARE TOLD TO DO SO

THIS BOOKLET CONTAINS 5 PRINTED PAGES INCLUDING COVER PAGE

QUESTION 1

a) Explain the power electronics switch in operation shown in Figure 1. (1 mark)

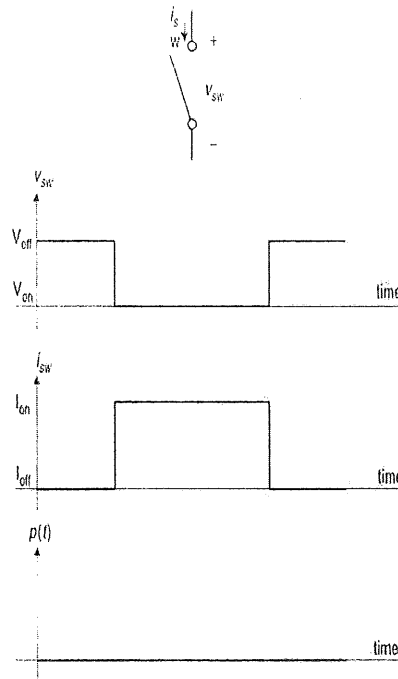

Figure 1

b) Given the circuit diagram in Figure 2.

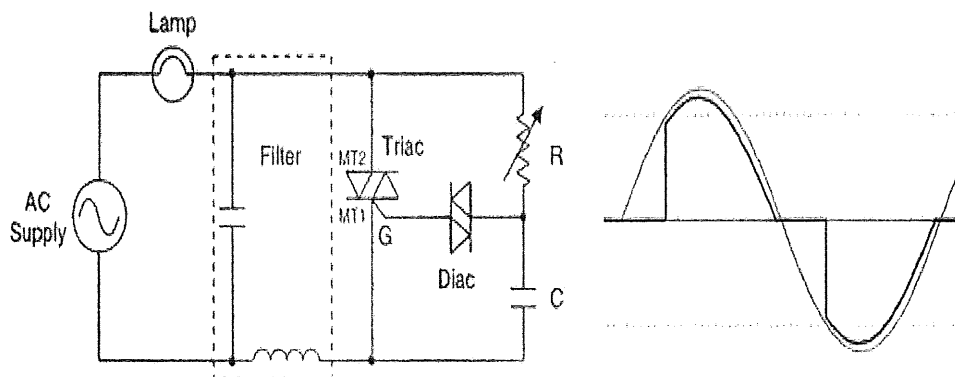
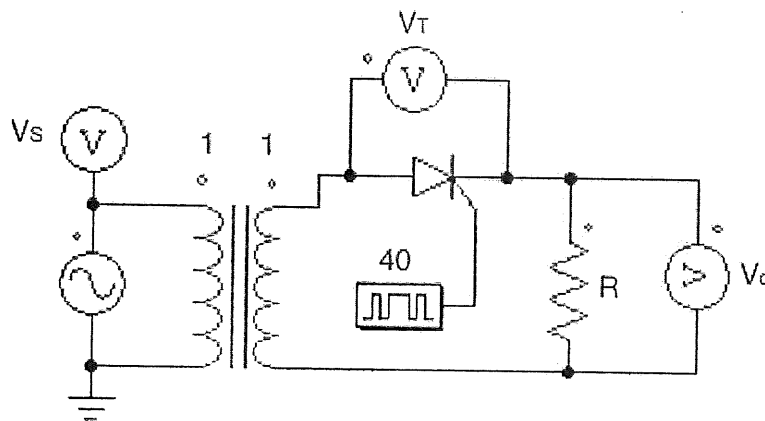

Figure 2

- i. Explain the triac operation. (2 marks)
- ii. Explain the diac operation. (2 marks)

QUESTION 2

- a) Figure 3 shows a rectifier with pure resistive load of $R=15\ \Omega$ and, $V_s=220\ \sin 314\ t$ and unity transformer ratio. Analyze the waveforms of the followings:
- Supply voltage, V_s (3 marks)
 - Load voltage, V_{out} (3 marks)
 - Supply current, I_s (3 marks)
 - Load current, I_{out} (4 marks)

**Figure 3**

QUESTION 3

a) Given the circuit diagram in Figure 4.

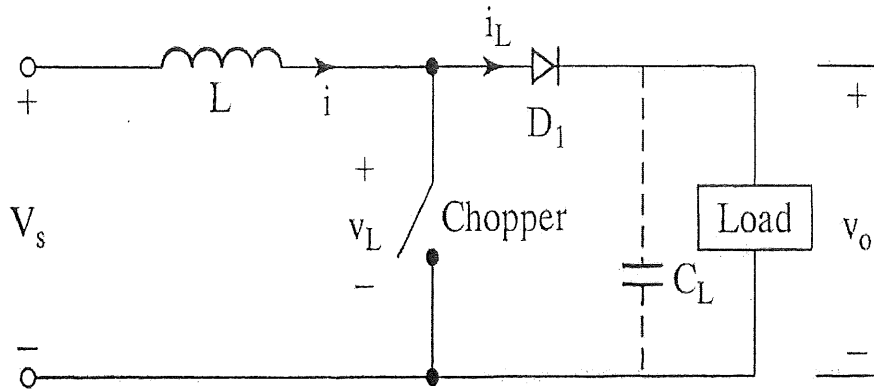
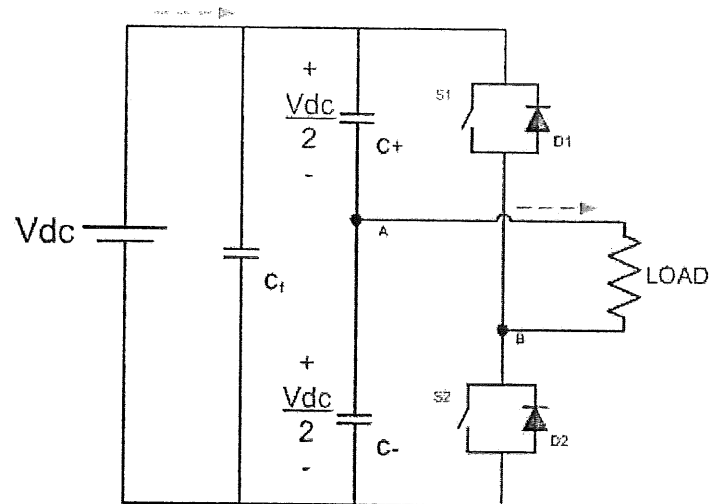

Figure 4

- i. Define the type of chopper circuit in Figure 4. (2 marks)
- ii. Explain the operation during switch ON and OFF. Include the circuit diagram representing both switching conditions. (11 marks)

QUESTION 4

- a) Define the DC to AC inverter. (2 marks)
- b) The circuit given in Figure 5 is VSI single-phase half-bridge inverter circuit topology. Solve the followings:

**Figure 5**

- i. Explain the function of capacitors, C+ and C-. (3 marks)
- ii. Explain the operation of switch ON and OFF circuit. (4 marks)

-----End of question-----

